



A Division of Sanweld Industries, Inc.

GH17 / GH25 Series Gas Hydraulic Salt & Sand Spreaders Owners & Operators Manual

Table of Contents

Warnings & Safety Precautions	P. 2
Spreader Start-Up Checklist.....	P. 3
Maintenance Requirements.....	P. 4
Installation Instructions.....	P. 5,6
Operating Instructions.....	P. 6
General Information.....	P. 7
Parts Breakdown Schematics.....	Pp. 8-12
Parts Lists.....	Pp. 13, 14
Troubleshooting.....	P. 15
Warranty.....	P. 16

Torwel Industries
A Division of Sanweld Industries, Inc. ♦ 19 Industrial Park Road East ♦ Oxford, MA 01540
(508) 987-8580 ♦ (508) 987-8550 Fax

-Warnings-

Do Not attempt to operate this Spreader until you have read and understand all warnings and instructions in the Owner's Manual and on the Spreader Unit. Failure to read and follow all warnings and instructions may lead to serious injury or death.



MOVING PART HAZARD

- NEVER enter hopper box while conveyor chain is moving.
- DO NOT RIDE on any part of the spreader while vehicle is in motion.
- Disconnect & lock out power source before adjusting or servicing.



TO AVOID INJURY

- DO NOT operate or service spreader without reading & understanding owner's manual & all warnings.
- AVOID unsafe operation & maintenance.
- KEEP unauthorized people away from equipment & controls.
- KEEP hands, feet, hair and clothing away from any and all moving parts.
- NEVER attempt to un-jam conveyor chain while engine is running.
- NEVER attempt to adjust or service spreader while engine is running.
- DO NOT stand behind material chute while spreader is discharging.
- DO NOT refuel a hot engine. Allow time to cool before refueling.
- DUMP BODY - For Utility Vehicles applications (i.e. J.D. Gator, Kawasaki Mule, etc.,) Dump Body Safety Chain must be attached to secure Dump Body & Prevent accidental release of Dump Body.
- For P/U Truck Applications must use P/N 1SM6 Optional P/U Truck Mount with Chute.

IMPORTANT

- DO NOT overfill spreader. (See decal on spreader for fill capacity.) If unit stalls, remove excess material above sidewalls, and / or check for obstructions on conveyor chain.
- Failure to keep conveyor chain links lubricated and free running can damage the conveyor chain, drive shafts and body structure.
- Failure to maintain conveyor chain or other components can void warranty.

Definitions of Hazard Levels

Identify hazard levels with the following symbols, signal words and definitions.



It Means: Immediate hazards which will result in severe personal bodily injury or death.



It Means: Hazards or unsafe practices which could result in severe personal injury or death.



It Means: BE ALERT! Your safety, or the safety of others, is involved.



GH17 / GH25 Gas Hydraulic Drive Salt & Sand Spreader

Complete this checklist prior to initial start-up and operation

- Read and understand Torwel's Owner's & Operations Manual**
- Read and understand Engine Manual**
- Read and understand all Warning Decals**
- Check Fuel Level**
- Check Engine Oil Level**
- Check Hydraulic Oil Level**
- Verify that Ignition/Low-Oil Cutoff Switch is in "On/Run" Position**
- Verify Hydraulic Shut-Off Valve is in "Open" position**
- Grease all Lubrication Points**
- Oil Conveyor Chain**
- Wire In-Cab Control Panel**
- Install Discharge Chute & Spinner Disc**
- Secure Top Screen using provided Locking Tab**
- Coat Harness Connector Ends with dielectric grease**
- Check Battery Connections**
- Verify Spreader is secure in vehicle using provided Ratchet Straps**

GENERAL MAINTENANCE REQUIREMENTS

- 1) Wash unit thoroughly after each use
- 2) Lubricate Bearings
- 3) Periodically lubricate conveyor chain with used engine oil
- 4) Disconnect battery when not in use for extended periods of time
- 5) Check engine & hydraulic oil every 5 hours or daily before use
- 6) Shut off fuel valve when not in use for extended periods of time
- 7) Change engine oil every 50 hours of operation or every season
- 8) Service engine air filter every 100 hours of operation or every season
- 9) Change hydraulic oil after 50 hours of operation or every season

See Page 7 in Owner's Manual for information regarding service and lubrication.

INSTALLATION INSTRUCTIONS

a) GH17/GH25 Spreader Hopper Installation

The GH17/GH25 Spreader is designed for mounting in the bed of most pick-up trucks. Four hold down assemblies are provided for securing the spreader easily to the truck bed.

Reminder: Any reference to directions concerning GH17/GH25 Spreader parts or as a whole, will be designated as viewing the equipment from the rear of the vehicle as it would normally travel.

Example:

Left	=	Driver's Side
Right	=	Passenger's Side
Front	=	Front of Vehicle
Rear	=	Rear of Vehicle

Remove the tailgate completely from the vehicle. Center the spreader to the bed of the truck and move as far forward as possible. Be sure to leave enough clearance for the material chute installation. Using the four hold down assemblies, secure the spreader to the truck bed.

Reference Figure # 1 (Page 8)

b) Spinner Shaft, Material Chute & Spinner Disc Installation

Install (1) pillow block bearing onto the lower end of the spinner shaft. Slide spinner shaft through existing pillow block bearing. Install (1) 3/16" roll pin in key slot on spinner motor shaft and slide spinner shaft onto spinner motor shaft. Tighten (2) set screws on spinner shaft. Install (1)

5/16" x 1 " bolt thru spinner shaft above the top pillow block bearing. Secure with (1) 5/16" nylon locknut. Mount the material chute to the corresponding holes in the left & right side plates. The material chute should be positioned so that the three adjustable deflectors are facing left, rear and right. Secure the material chute to the spreader using (4) 5/16"-18 x 1" hex head bolts with flat washers and nylon locknuts. Mount loose pillow block bearing to lower mount (in material chute) using (2) 3/8" bolts & nylon locknuts. Tighten all hardware including (2) set screws on each pillow block bearing. Mount the 14" spinner disc to the spinner shaft using (2) 3/4"-10 hex nuts & 1 lock washer.

Reference Figure # 2 (Page 8)

c) Cab Side Wiring Harness Installation

Important: The engine side harness for the spreader is already connected. Use care when connecting all wires and cables. A short in the wiring system may cause damage to the engine or the spreader electrical system.

Route the engine side wiring harness to the rear of the vehicle's cab. If a permanent location for the harness cable is preferred, find an unobstructed area behind the cab of the vehicle and drill a 1 7/8" diameter hole in the cab wall. A silicone based sealant may be used around the mounting surface for a watertight seal.

Installation Note: A horizontal connection between harness ends is recommended, as a vertical connection will allow water and moisture to enter the plug ends. If drilling is not desired, feed the cab side harness through the rear sliding window (if equipped), under the seat and to the dash. Leave enough cable at the plug end to allow an easy connection between spreader harness ends.

d) In-Cab Control Panel Installation

Connect the exposed wire terminal end of the harness cable to the control panel. When connecting wires, be sure that the ignition switch is in the "OFF" position. Mount the control panel to the underside of the dash board, making sure the control panel is grounded to the vehicle.

Installation Notice: When choosing a location for the control panel, do not position the panel in line with the driver's or passenger's seat so there is no possibility of hitting it in case of an accident.

OPERATING INSTRUCTIONS

a) Cab Controls

- 1) Verify that the ON/OFF switch is in the ON/RUN position.
- 2) Push in the ignition key (this will activate the electric choke) and turn to the "START" position. Once engine has started, release key to the "ON/RUN" position.
- 3) Flip the conveyor switch to the "ON" position (the indicator light will come on) to engage the conveyor chain and spinner disc.

b) Gate Height Adjustment

- 1) Loosen (2) gate screws
- 2) Adjust gate to the desired height
- 3) Tighten gate screws

Reference Figure # 4 (Page 10)

c) Material Chute Deflectors

Adjust the material deflectors to fine tune the spread pattern. Keep all material deflectors at the same angle.

For a large spread pattern: Raise Deflectors
For a small spread pattern: Lower Deflectors

Important: Never attempt to adjust material deflectors while the spreader is operating.

Reference Figure # 2 (Page 8)

d) Conveyor Chain Adjustment

Tighten both take-up bolts equally until slack is gone and the conveyor chain does not ride on the base support channels.

Adjustment Note: After adjusting the conveyor chain, verify that the take-up shaft is not cocked at an angle.

Important: Never attempt to adjust conveyor chain while spreader engine is running.

Reference Figure # 5 (Page 10)

GENERAL INFORMATION

a) Safety Precautions

- 1) DO NOT operate the spreader without first reading and understanding the Operator's Manual and All Warning Decals.
- 2) DO NOT lubricate or repair any moving parts while the spreader is running.
- 3) DO NOT go into the hopper body while the spreader is running.
- 4) DO NOT refuel a hot engine or while the engine is running.
- 5) DO NOT stand directly behind material chute while the spreader is discharging.
- 6) If conveyor chain becomes clogged, DO NOT attempt to loosen chain while the spreader is operating.
- 7) Keep hands, feet and loose clothing away from any moving parts.

b) Storage

- 1) Wash unit thoroughly
- 2) Oil conveyor chain
- 3) Lubricate all bearings
- 4) Disconnect battery

c) Lubrication

<u>Location</u>	<u>Lube Type</u>
Engine Oil	SAE 30
Hydraulic Oil	ISO Grade 32
Take-Up Bearings	Bearing Grease
4 Bolt Flange Bearings	Bearing Grease
Spinner Bearings	Bearing Grease
Conveyor Chain	Use Engine Oil

d) Service

<u>Location</u>	<u>Recommended</u>	<u>Interval</u>
Engine Oil	Check	Hours or Daily
Engine Oil	Change	50 Hours or 1 Season
Engine Air Filter	Check or Change	100 Hours or 1 Season
Spark Plugs	Check or Change	100 Hours or 1 Season
Harness Connectors	Check Condition	50 Hours or Monthly
All Bearings	Lubricate	50 Hours or Monthly
Conveyor Chain	Lubricate	100 Hours or 1 Season

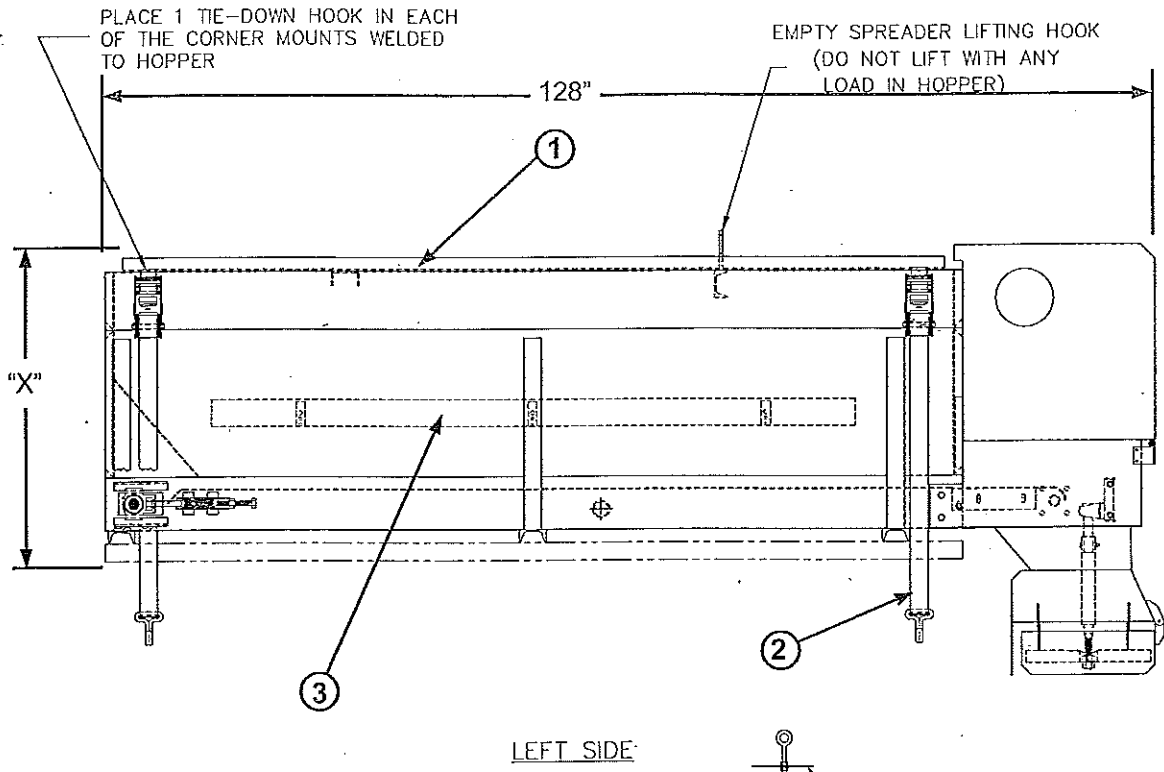

TS17/TS17A "X" = 35"
 TS25/TS25A "X" = 41"

LEFT SIDE

Reference Figure #1

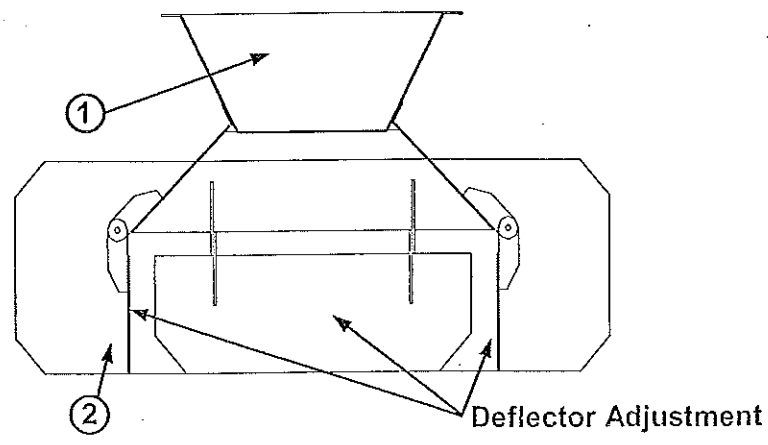
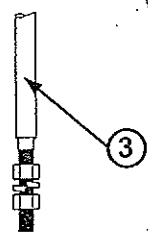

Reference Figure #2

ELECTRIC DIAGRAM

7 WAY PLASTIC HOUSING, HYDRAULIC DRIVE, WITH THROTTLE CONTROL.

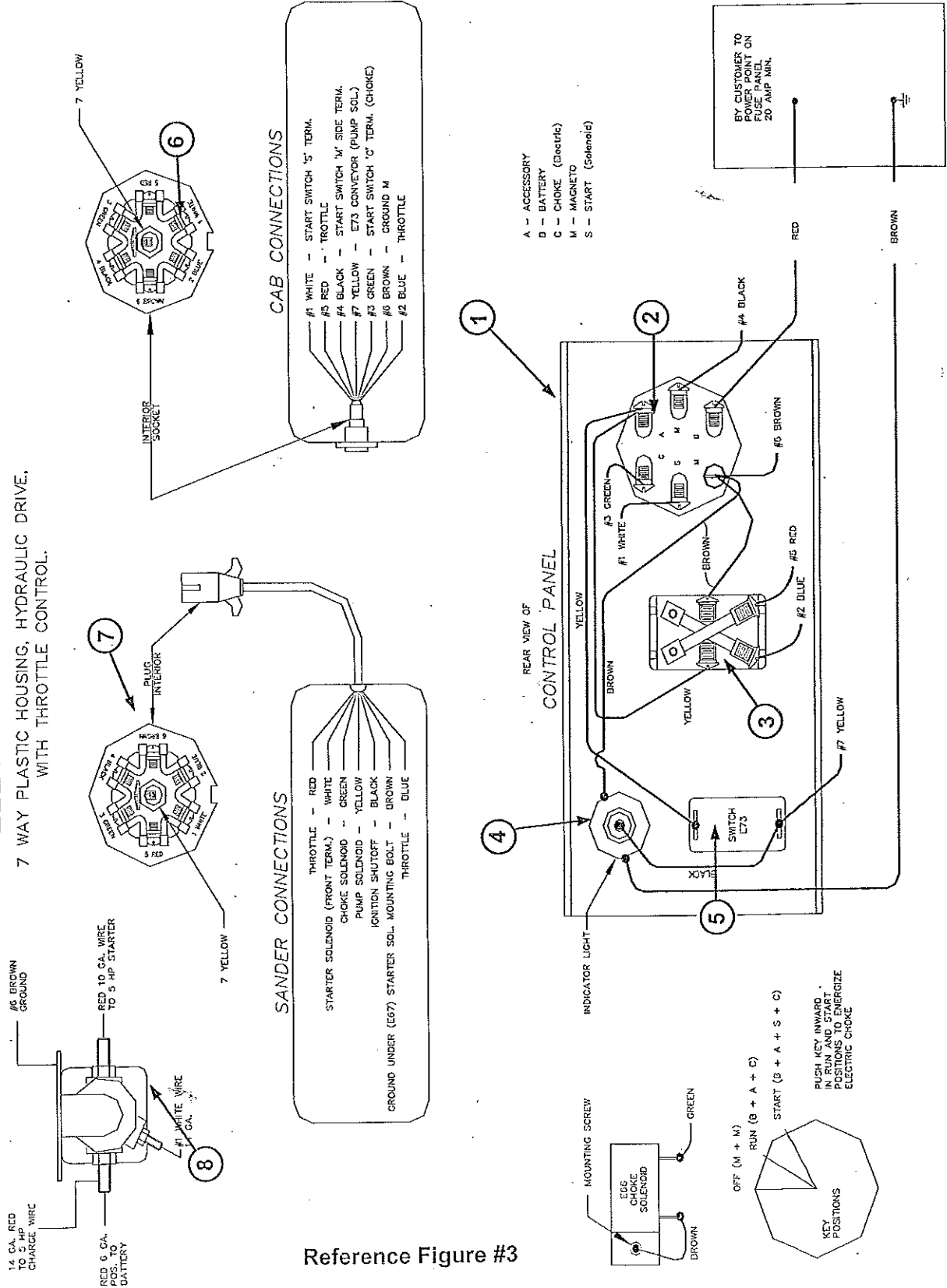

Reference Figure #3

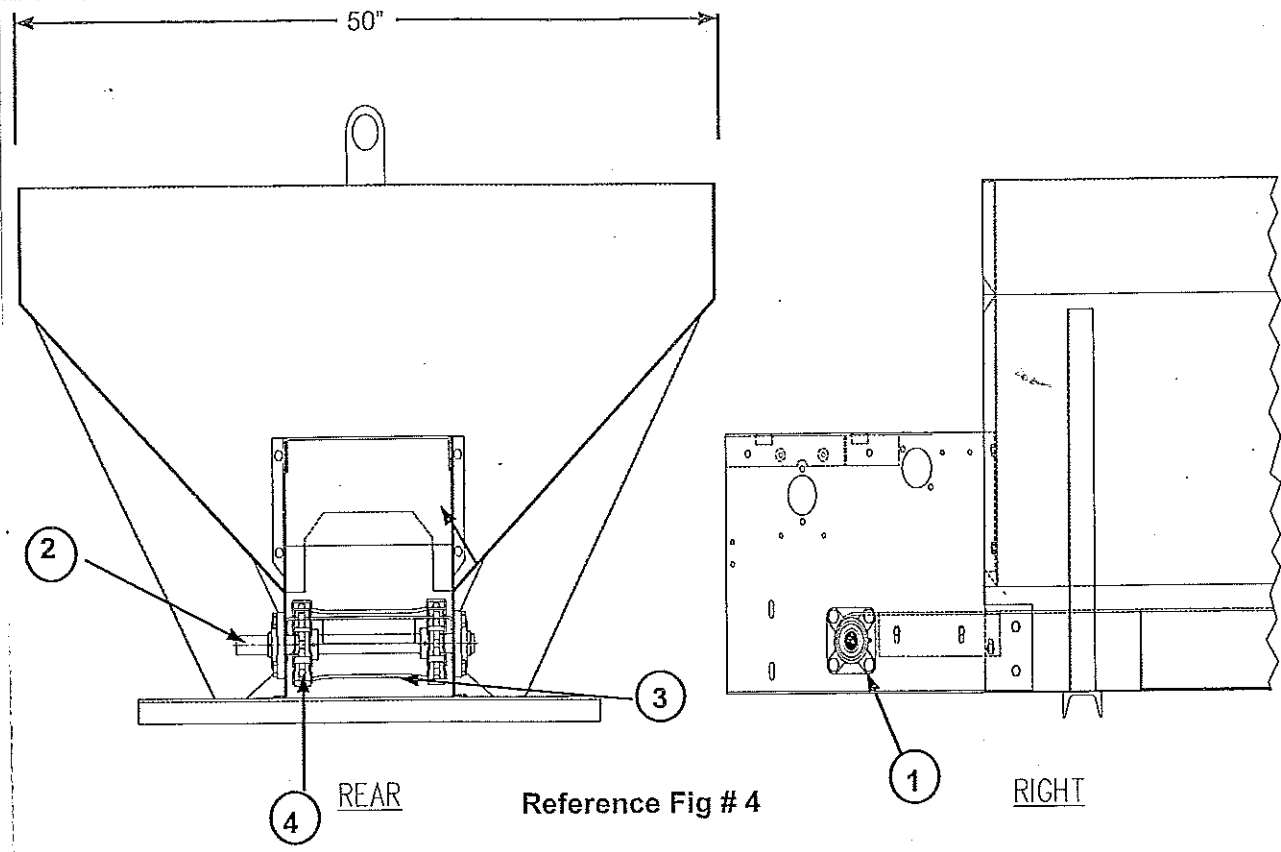

Reference Fig # 4

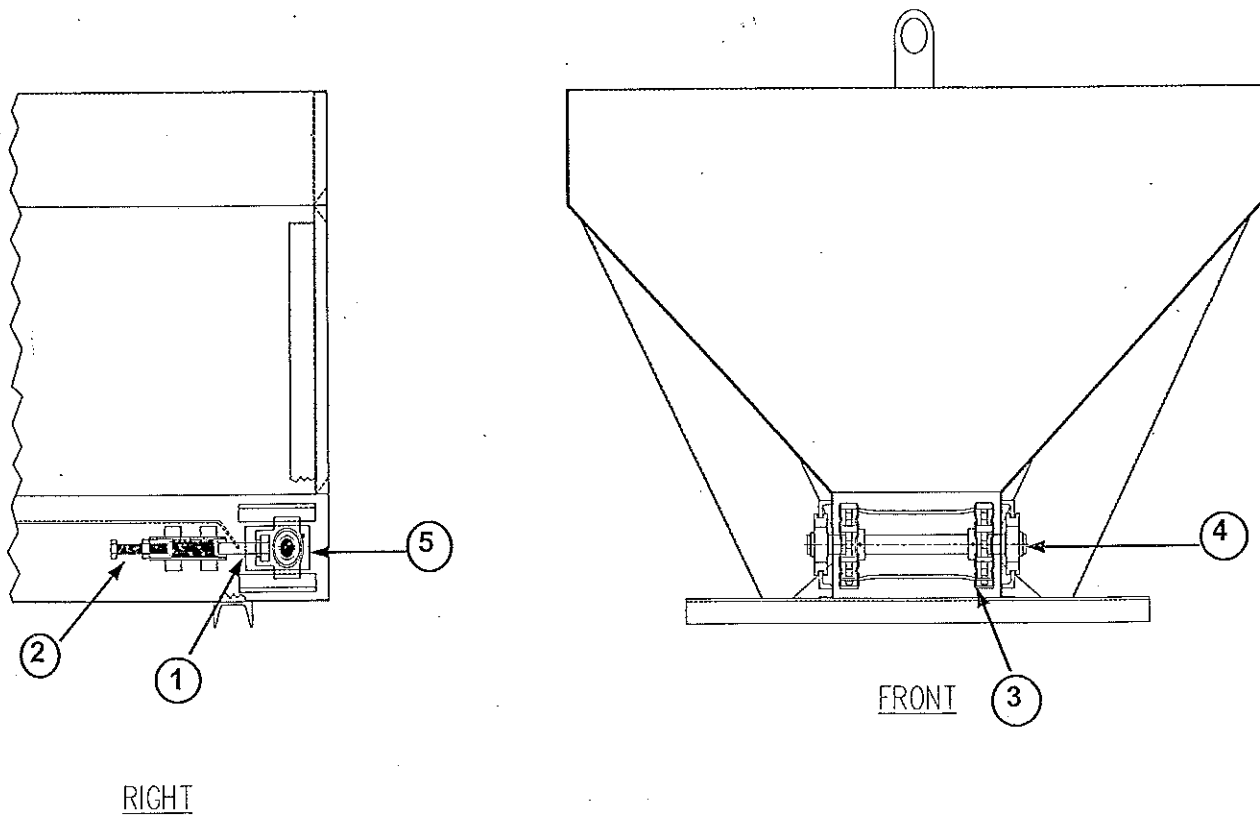

Reference Fig # 5

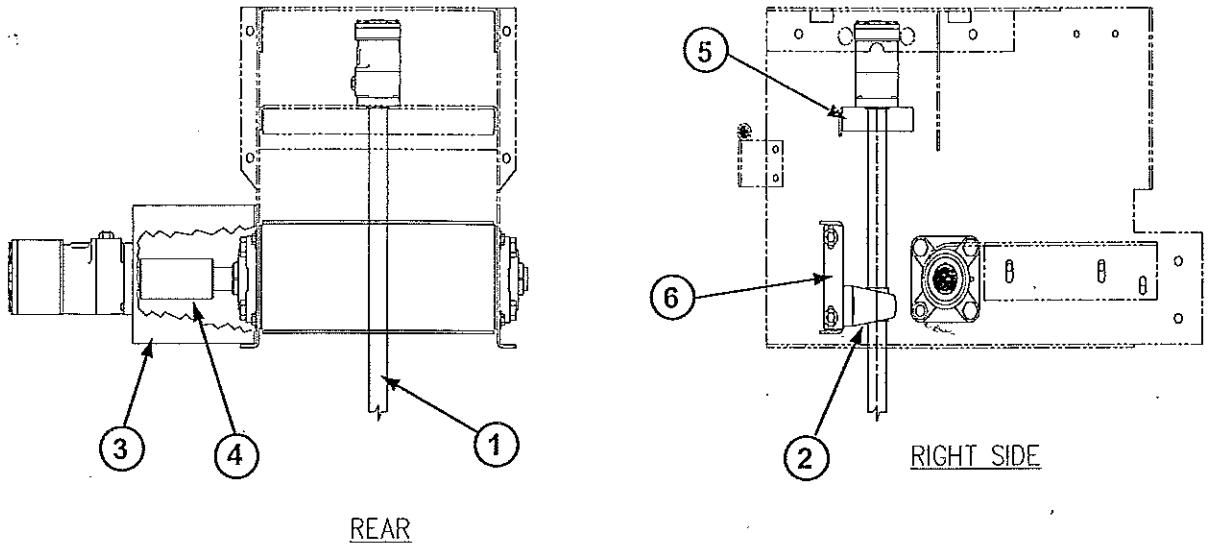

Reference Fig # 6

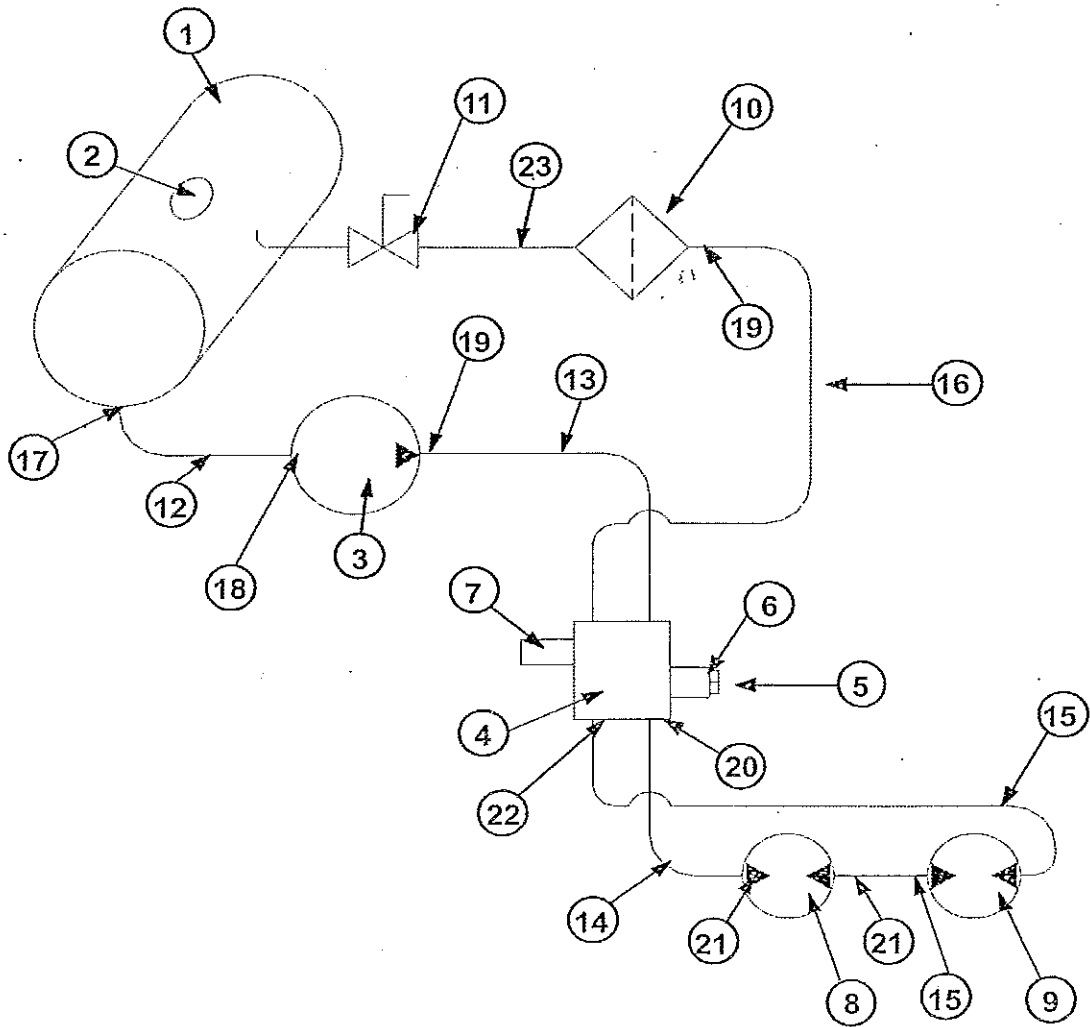

Reference Fig # 7

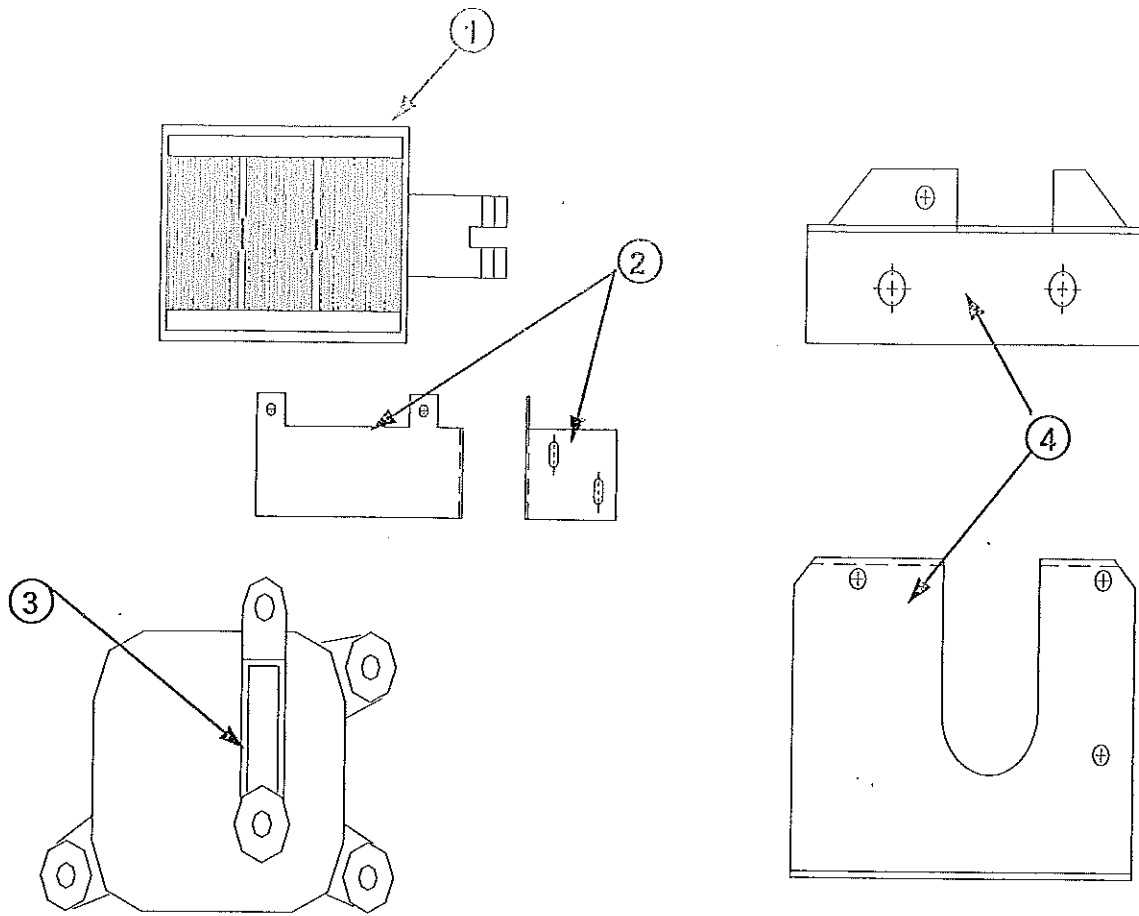

Reference Fig # 8

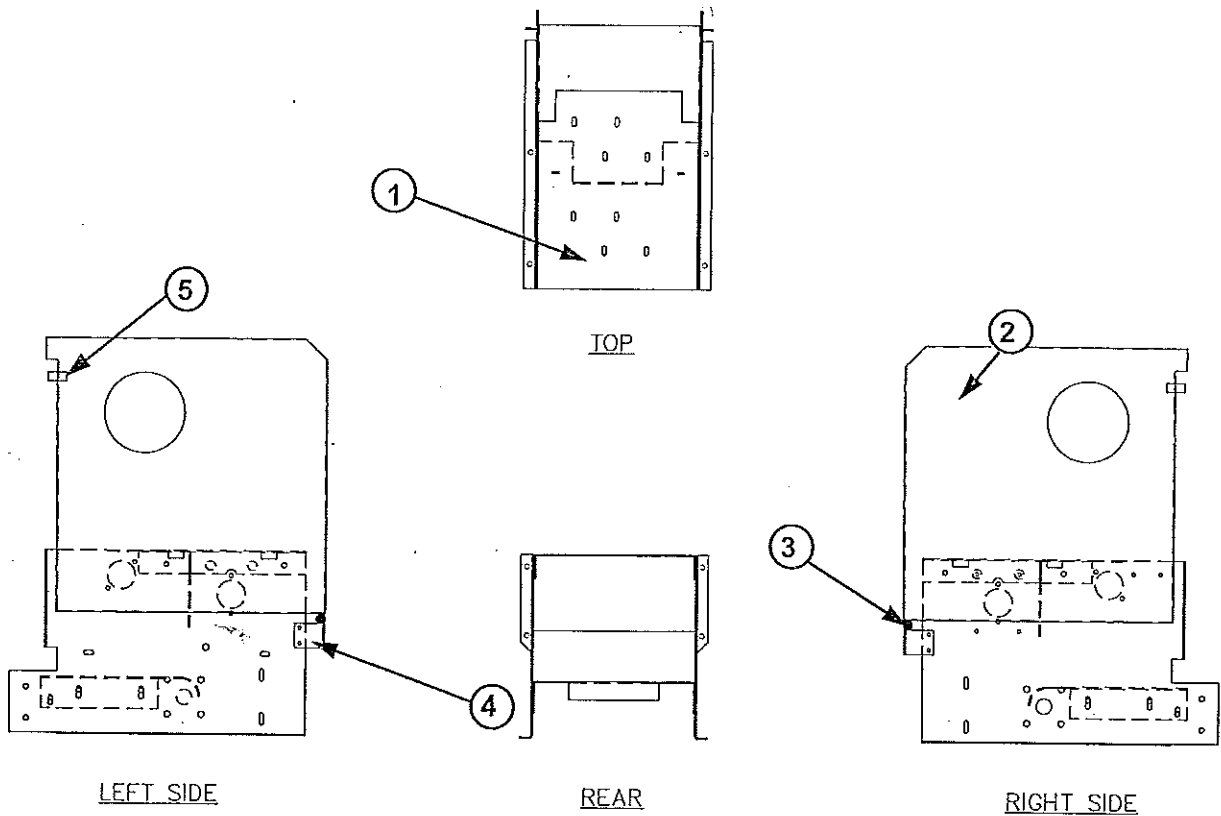

Reference Fig # 9

Spreader Accessories - Page #8, Fig. #1			
1	1TTS17-ESC-8	Top Screen - 8ft.	1
N/S	1TTS17-E134	Locking Clip For Top Screen	1
2	1TTS17-EHD	Heavy Duty Strap Assembly-All Inclusive (1 Only)	4
3	1TTS17-EINV	Inverted Vee Conveyor Bridge	1
N/S	1TTS17P2	Chute Extension Kit (Includes Shaft)	Optional
Discharge Assembly - Page # 8, Fig. # 2			
1	1TTS17-C7	Material Chute	1
2	1TTS17-E6	Material Deflector	3
3	1TTS17-C17A	Standard Spinner Shaft (21 1/4")	1
4	1TTS17-E18	14" Spinner Disc	1
N/S	1TTS17-EX19L	Pillow Block Mount (Lower)	1
N/S	1TTS17-E8C	Material Gate	1
Control Detail - Page # 9, Fig. # 3			
1	1TTS17-C70	Control Panel	1
2	1TTS17-C70B	Keyed Ignition Switch	1
3	1TTS17-C70C	Electric Throttle Switch	1
4	1TTS17-C70D	Pilot Light	1
5	9TTS01	Conveyor On/Off Switch	1
N/S	1TTS17-C44	Cab-Side Wiring Harness	1
6	1TTS17-C44A	7 Way Cab-Side Harness Plug End	1
N/S	1TTS17-C43	Spreader Side Wiring Harness	1
7	1TTS17-C43A	7 Way Spreader-Side Harness Plug End	1
N/S	1TTS17-C42	Battery	1
N/S	1TTS17-C42A	Battery Box	1
N/S	1TTS17-C42B	Battery Hold Down	1
N/S	1TTS17-C32N	Negative Battery Cable	1
N/S	1TTS17-C36P	Positive Battery Cable	1
8	1TBP61A	Starter Solenoid	1
Conveyor Assembly - Page # 10, Fig. # 4			
1	1TTS17-E13	4 Bolt Bearing	2
2	1TTS17-E14	Conveyor Drive Shaft	1
3	1TTS17-E15	Conveyor Chain	1
4	1TTS17-E11	8 Tooth Sprocket	4
Take-Up Assembly - Page # 10, Fig. # 5			
1	1TTS17-E101	BH Rivet - 5/8" x 4"	2
N/S	1TTS17-E103	Takeup Spring - 5"	2
2	1TTS17-E104	Takeup Bolt - 5/8"-11 x 5"	2
N/S	1TTS17-E106	BH Rivet - 1/2" x 1 1/4"	2
3	1TTS17-E11	8 Tooth Sprocket	4
4	1TTS17-E12	Takeup Shaft	1
5	1TTS17-E10	Takeup Bearing	2
Hydraulic Drive Assembly - Page # 11, Fig. # 6			
1	1TTS17-C17A	Spinner Shaft - 1" x 21-1/4"	1
N/S	1TTS17-EX36S	Spinner Shaft - 1" x 33 1/4" (Chute Extension)	1*
2	1TTS17-EX36P	Pillow Block Bearing	1
3	1TTS17-EH200	Conveyor Motor Bracket	1
4	1TTS17-T220208	Conveyor Motor Coupling (4")	1
5	1TTS17-C19M	Spinner Motor Mount Bracket	1
6	1TTS17-EX19	Pillow Block Mount (Upper)	1
N/S	1TTS17-C25-1	Pump Mounting Bracket	1
N/S	1TTS17-C25-C4	Pump Coupling	1
N/S	1TTS17-C25-C4A	3/4" Bore Coupling Half	1
N/S	1TTS17-C25-C4B	7/16" Coupling Half	1
N/S	1TTS17-C25-C4C	Coupling Insert (Nitrile)	1

Hydraulic Plumbing - Page # 11, Fig. # 7			
1	1TS17-C81	Hydraulic Reservoir	1
2	1TS17-C81-4	Filler Breather Assembly W/ Screen	1
3	1TS17-C4	Hydraulic Pump	1
4	1TS17-C83	Relief Block Complete	1
5	1TS17-C83-2	Solenoid Valve	1
6	1TS17-C83-3	12vdc Solenoid Coil	1
7	1TS17-C83-4	Relief Valve	1
8	1TS17-CCM-1	Conveyor Motor	1
9	1TS17-CSM-1	Spinner Motor	1
N/S	1TS17-C84-1	Filter Element	1
10	1TS17-C84-2	Filter Head Only	1
11	1TS17-C85	Shut-Off Valve	1
12	1TS17-CH96	Suction Hose (Reservoir to Pump)	1
13	1TS17-CH97	15" Hose Assembly (Pump to Relief Block)	1
14	1TS17-CH99	14" Hose Assembly (Relief Block To Conv. Motor)	1
15	1TS17-CH94	18 1/2" Hose Assembly (Conv. To Spin/Spin to Relief Block)	2
16	1TS17-CH98	13" Hose Assembly (Relief Block to Filter Head)	1
17	1TS17-C86	Elbow - 90 deg. Male NPT x JIC -8-8 (Reservoir Suction)	1
18	1TS17-CH96A	Hose Coupling Male Barb x Male NPT -8-6 (Pump Inlet)	1
19	1TS17-C92	Elbow - 90 deg. Male NPT x JIC -6-6 (Pump Outlet/Filter In)	2
20	1TS17-C93	Elbow - 90 deg. Male NWO x JIC -6-6 (Relief Block to Conv.)	1
21	1TS17-C89A	Elbow - 90 deg. Male NPT x JIC -6-8 (Conv. Motor)	2
22	1TS17-C88	Adapter - Male O-Ring x JIC -6-6 (Relief Block to Spin)	1
23	1TS17-C91	Adapter - Male NPT x Male NPT -6-6 (Filter Head to Shut-Off)	1
Engine Electrical - Page # 12, Fig. # 8			
1	1TS17-E66	Choke Solenoid	1
N/S	1TS17-E66-1	Choke Return Spring	1
2	1TS17-C69-TC	Tecumseh Choke Bracket	1
3	1TS17P4-1	Electric Throttle Motor	1
4	1TS17-C69BT	Tecumseh Throttle Bracket	1
N/S	1TS17-C75-5TT	Throttle Motor Push-Rod	1
N/S	1TS17-C25-T	5 hp Tecumseh Engine	1
Engine Housing - Page # 12, Fig. # 9			
1	1TS17-C02-K	Rear Mount Assembly	1
2	1TS17-C3	Engine Cover (Hood)	1
3	1TS17-E3-10D	Hinge Rod	1
4	1TS17-E3-10	Hood Hinge	2
5	9PRTM	Hood Latch	2
Miscellaneous Stainless Steel Spreader Parts			
(3) Fig #1	1TS17A-EINV	Inverted Vee Conveyor Bridge	1
(5) Fig #6	1TS17A-C19M	Spinner Motor Mount Bracket	1
(2) Fig #9	1TS17A-C3	Engine Cover (Hood)	1
(1) Fig #2	1TS17A-C7	Material Chute	1
(2) Fig #2	1TS17A-E6	Material Deflector	3
N/S	1TS17AP2	Chute Extension Kit-Stainless Steel (Includes Shaft)	Optional
(1) Fig #9	1TS17A-C02-K	Rear Mount Assembly	1
(6) Fig #6	1TS17A-EX19	Pillow Block Mount (Upper)	1
N/S	1TS17A-EX19L	Pillow Block Mount (Lower)	1
N/S	1TS17A-E8C	Material Gate	1
N/S	1TS17A-C42A	Battery Box	1
N/S	1TS17A-C42B	Battery Hold Down	1

Troubleshooting

Engine/Electrical		
Symptom	Possible Problem	Solution
Engine Will Not Start	On/Off Switch on Engine in OFF Position	Put On/Off Switch in ON Position
	Fuel Tank Empty	Add Fuel
	Water in Fuel	Drain Fuel Tank, Add Fresh Fuel
	Loose Wiring Connection	Visually inspect Harness Connections
Engine Will Not Turn Over	Weak Battery	Check Condition of Battery & Connections
Engine Will Not Shut Off	Bad or Missing Ground at Control Panel	Ground Control Panel to Vehicle
Engine Smokes While Running	Clogged Air Filter	Clean or Replace Air Filter
	Overfilled Oil Level in Engine	Check Engine Oil Level
Battery Will Not Charge	Bad or Missing Ground At Control Panel	Ground Control Panel to Vehicle
	Bad or Missing Ground at Battery Ground Lead	Clean Battery Ground Lead Connection to Spreader Body
Engine Will Not Choke	Misaligned or Corroded Choke Solenoid Plunger	Verify Choke Solenoid Plunger is Operating Straight. Clean Corrosion from Plunger
	Choke Plunger Doesn't Move	Lubricate Plunger with WD40
General Engine Questions		Refer to Engine "Owner" Manual"
Conveyor		
Symptom	Possible Problem	Solution
Not Enough Material Being Spread	Gate Not Adjusted Properly	Open Gate for Desired Amount of Material
Too Much Material Being Spread	Gate Not Adjusted Properly	Close Gate for Desired Amount of Material
Conveyor Chain Has Too Much Slack	Take-Up Bearings Out Of Adjustment	Adjust Take-Up Bolts at Front of Spreader. Tighten Bolts to reduce Slack.
Take-Up Bolts Have no Adjustment Left	Conveyor Chain has Stretched	Loosen Take-Up Bolts Completely. Remove Links from Conveyor Chain. Re-Adjust Take-Up Bolts.
Conveyor Chain Does Not Move	Debris or Frozen Material Stuck in Conveyor Chain.	Dislodge Material From Conveyor Chain.
	No Power to Conveyor Solenoid	Verify Conveyor Switch is Getting Power.
		Check & Inspect Harness Connections.
		Verify Connection at Conveyor Solenoid.
Spinner		
Symptom	Possible Problem	Solution
Spread Pattern Too Narrow	Engine Speed Too Slow	Increase Throttle to Engine
Spread Pattern Too Wide	Engine Speed Too Fast	Reduce Throttle to Engine
Spinner Disc Does Not Turn	Loose Connection Between Shaft & Disc	Tighten Mounting Nuts on Shaft
Spinner Disc Vanes Wear Early	Suspect Material	Check Material Being Spread for Rocks

